

KIT PRODUCT TECHNICAL DATASHEET

KIT MONOS4

Brushless 

Intensive use 

Digital Encoder 



Composition KIT MONOS4

CODE	DESCRIPTION	QTY
MONOS4	Electromechanical actuator with telescopic arm, BRUSHLESS, low voltage, super intensive use, with native encoder onboard, irreversible, ideal for swing gates with leaf up to 4 m length.	2
B70/2DC/BOX	Digital control 24V for 2 BRUSHLESS motor, with plastic box.	1
H93/RX20/I	Plug-in receiver 2 channels 433,92 Mhz (50 Storable codes) for control unit series H70, B70, EDGE and CTRL.	1
SYNUS/2	Dual code transmitter (modality fixed code or rolling code), 433,92 Mhz. 2 channels, with radio for copy.	2
R90/F4ES	Pair of external photocells synchronized 24V AC/DC (max. 4 pairs).	1
FIFTHY/24	LED flashing light series FIFTHY 24V with integrated antenna.	1
R99/C/001	Signboard "Automatic Opening"	1

PRODUCT TECHNICAL SPECIFICATIONS

Power line supply	230V AC - 50Hz
Motor power supply	24V
Power rating	200W
Frequency of use	Intensive use
Thrust	2200N
Operating temperature	-20 C° +55 C°
Protection level	IP43
Reductor Type	Irreversible
Manoeuvre speed	2,10 cm/s
Opening time at 90°	19-35 s
Stroke	400 mm
Limit switch	-
Recommended digital controllers	-

Encoder	Digital native encoder SENSORLESS 48 PPR
Operating cycles per day (opening/closing - 24 hours no stop)	700
Maximum dimension product in mm (L x W x H)	1223 x 178 x 111
Product weight packed (Kg)	18,8
Number items per pallet	21

PRODUCT DIMENSIONS AND PREPARING FOR INSTALLATION

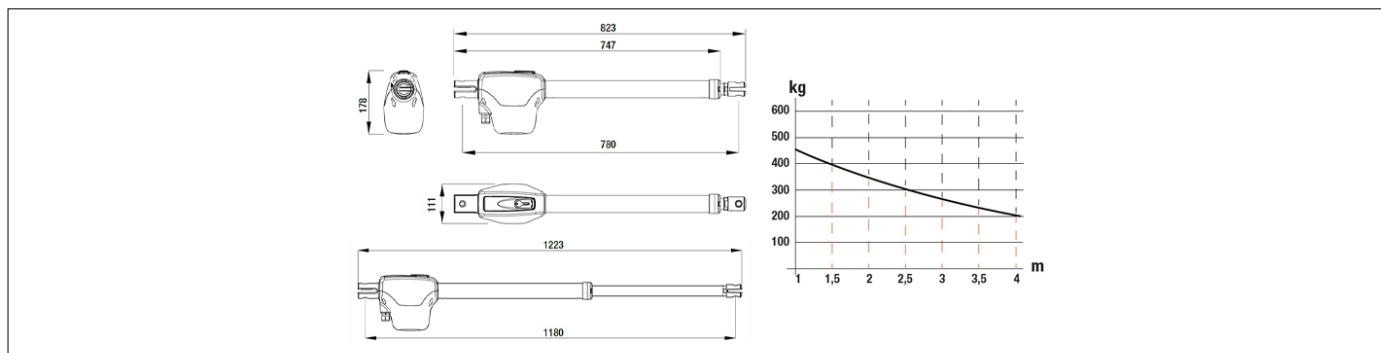

DIMENSIONS

PRODUCT PREPARING FOR INSTALLATION

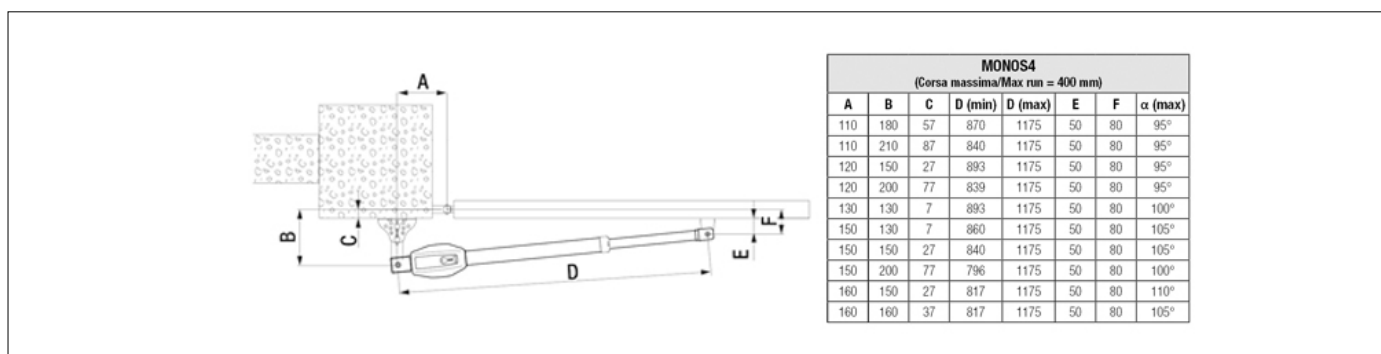

PREDISPOSITION FOR STANDARD INSTALLATION

PRODUCT ACCESSORIES

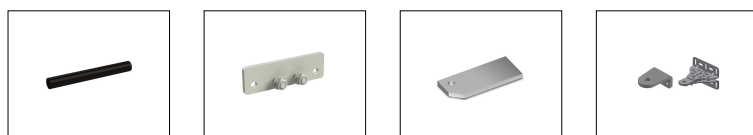

HT420
MONOS4 Series stem cover.

KT248
Front bracket support with M8 pins for MONOS

KT204
Short rear hinge plate to weld.

KT246
Kit of screw adjustable short rear bracket and front bracket to screw (MONOS4).